

**Caudal**3.5 m³/h**Altura manométrica**

10 m

Potencia

0.18 kW

Bomba horizontal de arrastre magnético para el trasvase de fluidos corrosivos

LÍQUIDOS CORROSIVOS

Líquidos corrosivos
Fluidos densos
Traslado de baños

VENTAJAS

Auto-reprimido
Excelente rendimiento
Excelente resistencia a ácidos y bases
Transferencia por baño galvánico

CONEXIONES

Racor roscado
Rosca macho
Virolas
Bridas

ESPECIFICACIONES**Rendimiento hidráulico**

Caudal máximo (m ³ /h)	3.5
Altura manométrica máximo (m)	10
Temperatura máxima (°C)	80 (PP) - 110 (PVDF)
Densidad	< 1.4

Motor

Estándar	N/A
Alimentación (V)	230 Monofásico
Potencia (kW)	0.18
Frecuencia (Hz)	50 - 60
Velocidad de rotación (tr/min)	3000

Diseño

Tecnología	Arrastre magnético
Materiales disponibles	Polipropileno (PP) Fluoruro de polivinilideno (PVDF)
Sellos	Cerámica / cerámica o grafito / cerámica
Juntas	EPDM (PP) FPM (PP - PVDF) PTFE (PP - PVDF)



SIEBEC SAS
contact@siebec.com



SIEBEC Ltd
sales@siebec.co.uk



SIEBEC S.L.
ventas@siebec.com



SIEBEC SRL
commerciale@siebec.com



SIEBEC GmbH
info@siebec.de



SIEBEC LDA
info.pt@siebec.com

Estamos aquí para ayudarte.
Contacto con nosotros !



DIMENSIONES

Unidades : mm

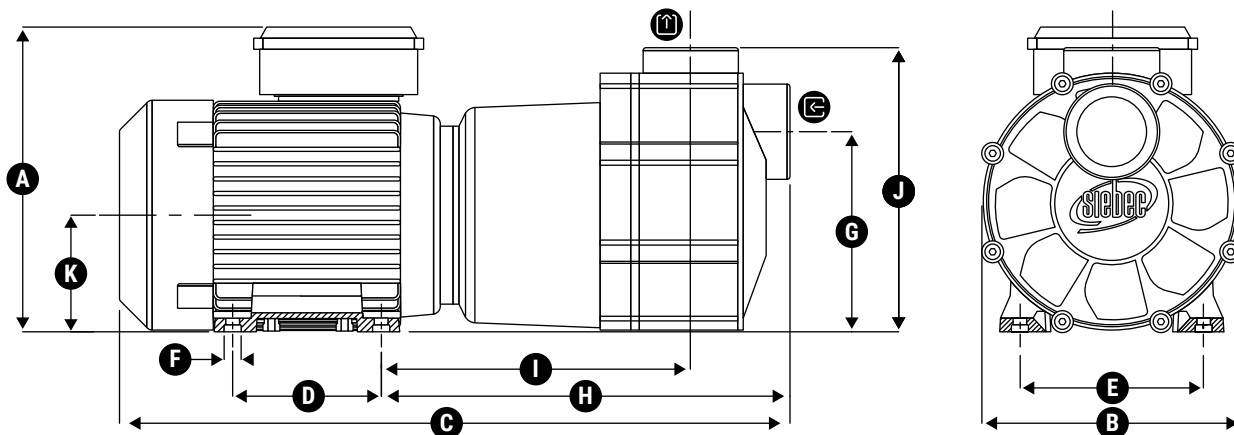

Dimensiones del contorno			Fijación			Entrada / Salida					
A	B	C	D	E	F	G	H	I	J	K	L
153	138	346	80	100	Ø7(x4)	107	202	150	153	68	N/A

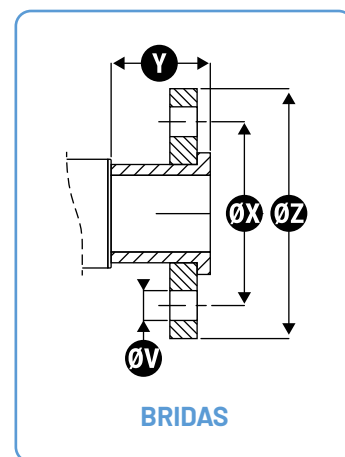
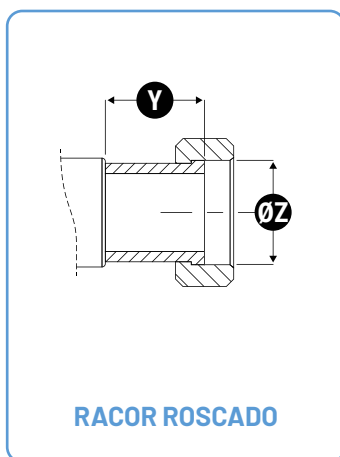
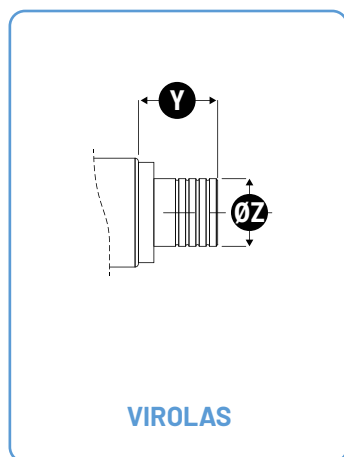

	Violas		Racor roscado		Bridas			
	Y	Z	Y	Z	Y	Z	X	V
Entrée	65	Ø20	31.5	G1"1/4 DN20	31.5	Ø100 - DN20	Ø 75	4 x Ø12
Sortie	65	Ø20	31.5	G1"1/4 - DN20	31.5	Ø100 - DN20	Ø 75	Ø12 (x4)



CURVA DE CAUDAL

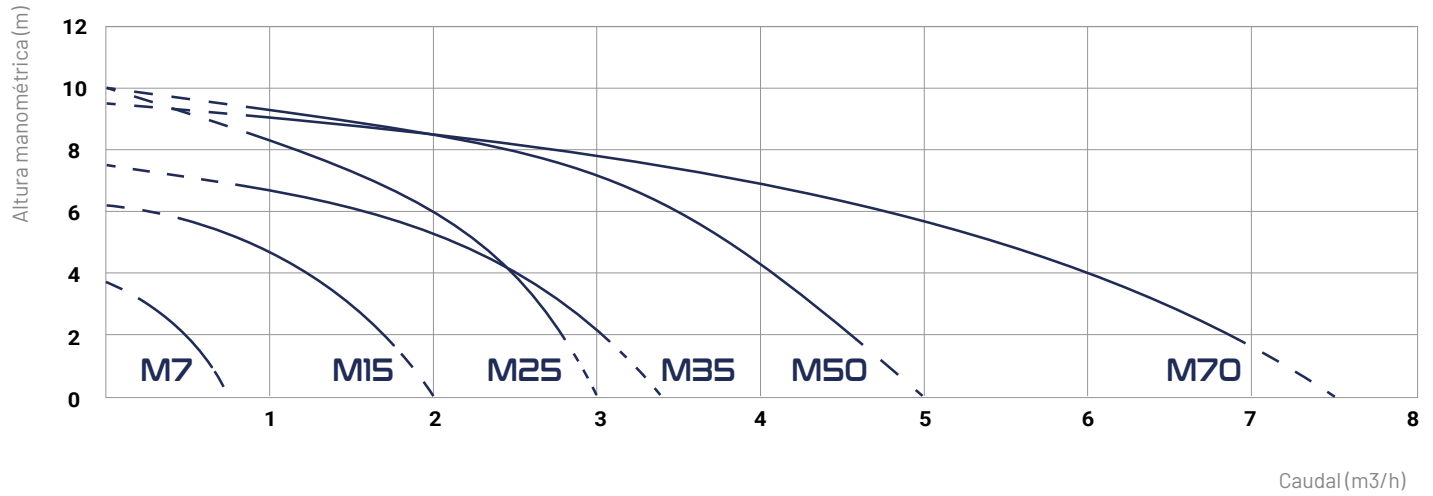

NPSH CURVA

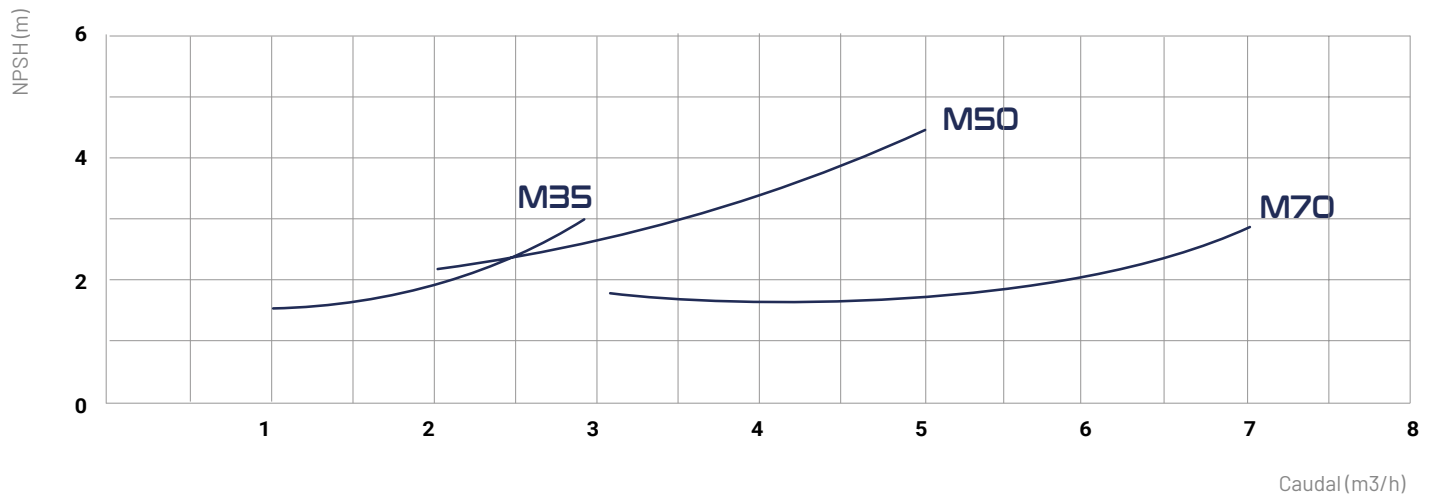

EFICIENCIA CURVA

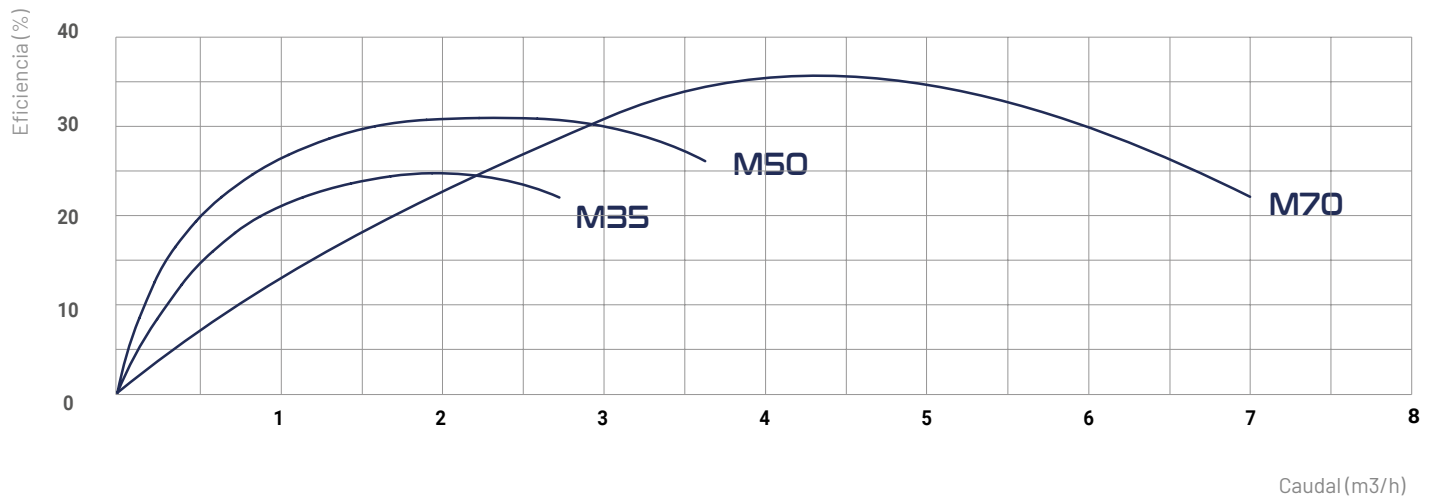

FT-SI-M-SERIES-M35-ES



SIEBEC BOMBAS DE ARRASTRE MAGNÉTICO

M SERIES

	Caudal (m³/h)	Altura manométrica (m)	Potencia (kW)	Densidad	Alimentación (V)
M7	0.7	4	0.01	1.2	230 Monofásico
M15	2	6	0.045	1.2	230 Monofásico
M25	3	7	0.12	1.1	230 Monofásico
M35	3	10	0.18	1.4	230 Monofásico
M50	5	10	0.18	1.2	230 Monofásico
M70	7	9.5	0.25	1.2	230 Monofásico
M100	10	18	0.75	1.5	230 / 400 Trifásico
M140	16	19	1.1	1.5	230 / 400 Trifásico
M200	21	20	1.1	1.5	230 / 400 Trifásico
M250	26	19	1.5	1.2	230 / 400 Trifásico
M290	31.5	21.5	2.2	1.5	230 / 400 Trifásico
M390	43	22	3	1.3	230 / 400 Trifásico



SIEBEC SAS
contact@siebec.com



SIEBEC Ltd
sales@siebec.co.uk



SIEBEC S.L.
ventas@siebec.com



SIEBEC SRL
commerciale@siebec.com



SIEBEC GmbH
info@siebec.de



SIEBEC LDA
info.pt@siebec.com

Estamos aquí para ayudarte.
Contacto con nosotros !

