

ELECTROLYTIC METAL RECLAIMER

The unit is designed for the electrolytic recovery of metals contained in concentrated or diluted solutions. It finds its principal applications in the recovery of precious metals (Au, Ag, Pd...), however it can also be used for the recovery of toxic metals in waste waters.

Its main application are for the recovery of :

- **precious metal** (Au, Ag, Pd...).
- the recovery of **toxic metals** (heavy) in used waters.



Technical features

| | |
|------------------------|------------------------------|
| Materials | PP - PVDF |
| Max temperature | 60°C |
| Filtration | On patented Siebec cartridge |
| Pumps | M15 - M35 |
| Flowrate | 1,8 to 3 m ³ /h |
| Connections | Threaded - grooved nozzle |

Electrum ® advantages

- ♦ **High capability for recovery of metals** : high pump capacity allowing a large number of turnover in a short scale of time.
- ♦ **Deposit trapped inside the cartridge** : no more loss of metals going back into the solutions.
- ♦ **Easy to melt and refine.** : recovered metals quickly back in process.
- ♦ **Efficient on all metals** : operating methods available for different materials such as Gold, Palladium, Silver and others in concentrated or rinse bath.
- ♦ **Destruction of cyanide** : the addition of 10 to 20 g/l of the ECN additives creates a continuous, destruction of cyanides while the electrolytic recuperation process.
- ♦ **Recuperation of the Palladium in ionic solutions** : the Palladium is recovered by the use of the Pd special cartridges.
- ♦ **Recuperation of the Palladium in colloids** : addition of the EPd additive and the use of a special cartridge allow the recuperation of the Palladium in colloidal solutions .
- ♦ **Recuperation in Gold Strip** : the addition of 10 to 20 g/l of the EAU additive make possible the gold recuperation in gold strip bath.
- ♦ **Patented** : a large manufacturing company and well organised customer services to help you on advices.
- ♦ **Amount of metal recovered known by weight** : calculate and monitor your own material recuperation, data often important production.
- ♦ **Quick return on investment** : the more the recovery the more return on the investment you will have.

ELECTROLITYC METAL RECLAIMER

Working principle



Captive cartridge

- ♦ **The deposit is kept within the cartridge**
- ♦ **Avoid any loss of metal, even if the deposit is "burnt"**
- ♦ **Invisible deposit**
- ♦ **Possibility to know the weight of the deposit by simple weighing before and after**
- ♦ **Easy to melt and refine**



The Electrum® recovery cartridge (patented) is a porous and combustible container in which the metal extracted from the solution is deposited. The porosity of the walls has been calculated in order to let circulate the liquid but to keep metallic particles inside. When this operation of recovery is finished, the cartridge is rinsed, dried, weighted and sent for treatment where it is burnt. The metal is then melted and refined without any difficulty.

ELECTROLYTIC METAL RECLAIMER

M15 dimensions

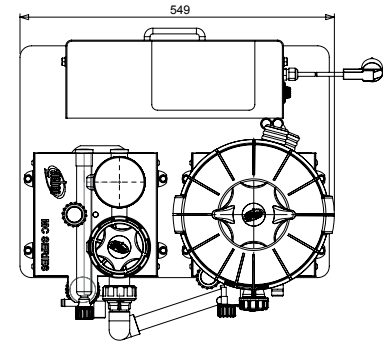
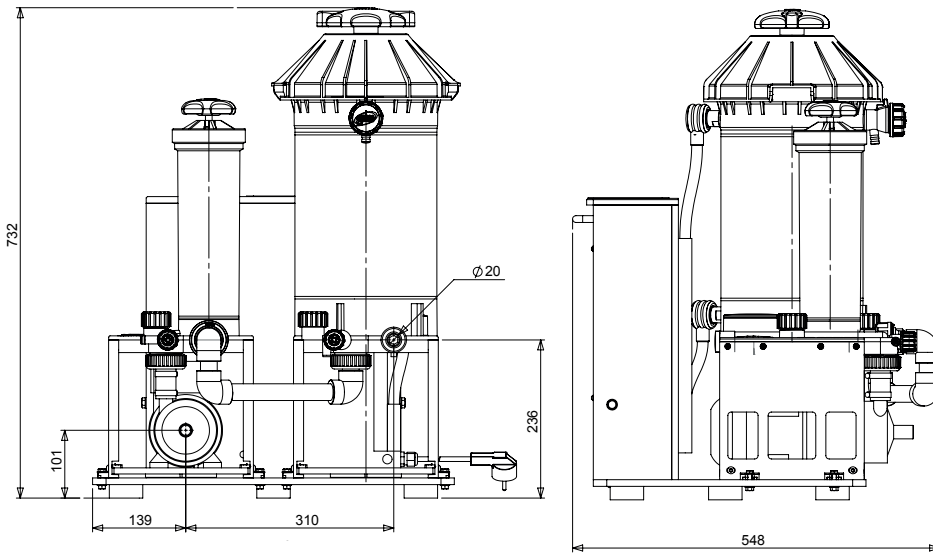

Magnetic pump M15
~ 0.045 kW, ~ 1800 l/h

- Volume of liquid contained in the display :** nearly 10 liters
- Maximum temperature of use :** 60 °C
- Electrical input :** 220 volts single-phase 50 Hz, Plugs: E.C certified
- Power consumption :** 330 VA (1,5 A)
- Rectifier :** 15 Amperes, 10 volts, direct current, stabilized intensity or voltage
- EC Certified :** Protection against excess current by fuse and general circuit breaker

Identification ELECTRUM

SIRELEC 52799 - 2.5" } Ø cartouche CAPTIVE
4"

M35 dimensions

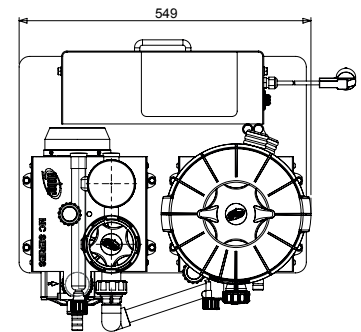
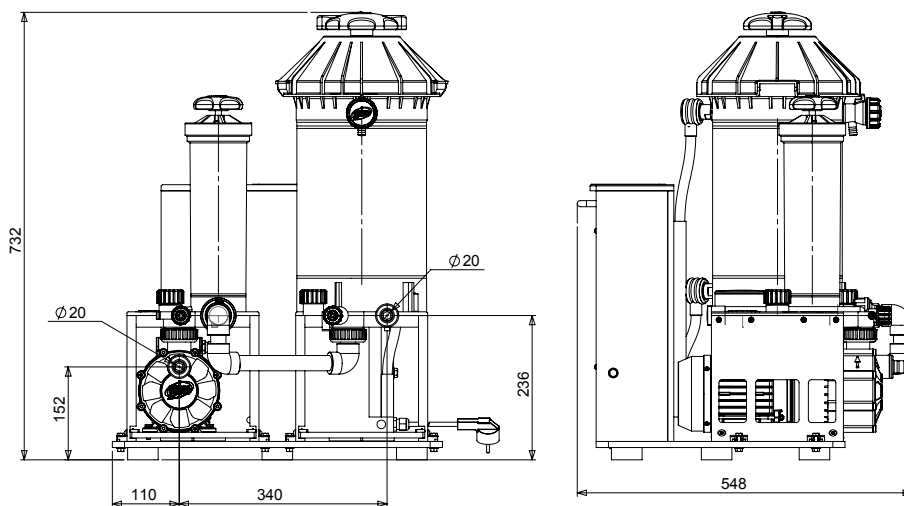

Self priming magnetic pump M35
~ 0.18 kW, ~ 3000 l/h

- Volume of liquid contained in the display :** nearly 10 liters
- Maximum temperature of use :** 60 °C
- Electrical input :** 220 volts single-phase 50 Hz, Plugs: E.C certified
- Power consumption :** 330 VA (1,5 A)
- Rectifier :** 15 Amperes, 10 volts, direct current, stabilized intensity or voltage
- EC Certified :** Protection against the sur-intensity by fuse and general circuit breaker.

Identification ELECTRUM

SIRELEC 52808 - 2.5" } Ø captive cartridge
4"