



M7 - M15 - M25 magnetic drive pumps catalogue



 *Presentation of the range*

 *Curves*

Applications : surface treatment, transfer, pumping of chemicals, water treatment, paper industry, agribusiness, cosmetics industry, fish farming, metallurgy.

Features	Advantages
Pump body made of injected plastic (Polypropylene or PVDF)	Excellent resistance to acids and bases Max. fluid temperature = 80°C
Closed centrifugal pump impeller with diffusion part	Very good efficiency Max. flow rate up to 3.8 m ³ /h Max. manometric head up to 7 m
Impeller driven by high capacity magnetic coupler	No gaskets, no risks of leaks Compatible with fluids of S.G. up to 1.2 according to models
Integrated electric motor	Reduced dimensions



M7 - M15 - M25 magnetic drive pumps

230 V 1 ph motor or 230/400 V 3 ph motor (except M7)- 50 Hz or 60 Hz upon request - 2,900 rpm

Standard inlet/outlet with grooved nozzles

Optional union nuts or flange fittings except on M7 pump, union nuts only on M15 pump.

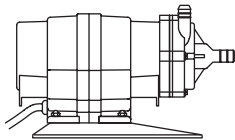

M7 pump

Technical features

- Motor power 0,01 kW one-phase motor
- Max. output 0.7 m³/h
- Max. head 4 m CE
- Max. fluid temperature PP body 80°C
- S.G. < 1.2
- Gaskets EPDM - FPM

DIMENSIONS



CURVES

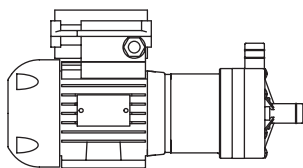

M15 pump

Technical features

- Motor power 0,045 kW one-phase or three-phase motor
- Max. output 2 m³/h
- Max. head 6 m CE
- Max. fluid temperature PP body 80°C
- S.G. < 1.2
- Gaskets EPDM - FPM

DIMENSIONS



CURVES

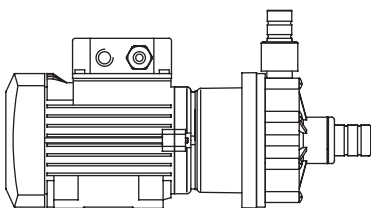

M25 pump

Technical features

- Motor power 0.12 kW one - phase or three - phase motor
- Max. output 3.8 m³/h
- Max. head 7 m CE
- Max. fluid temperature PP body 80°C
- S.G. < 1,1
- Gaskets EPDM - FPM

DIMENSIONS

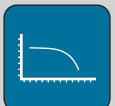

CURVES



M7 - M15 - M25 pumps

Magnetic drive pumps

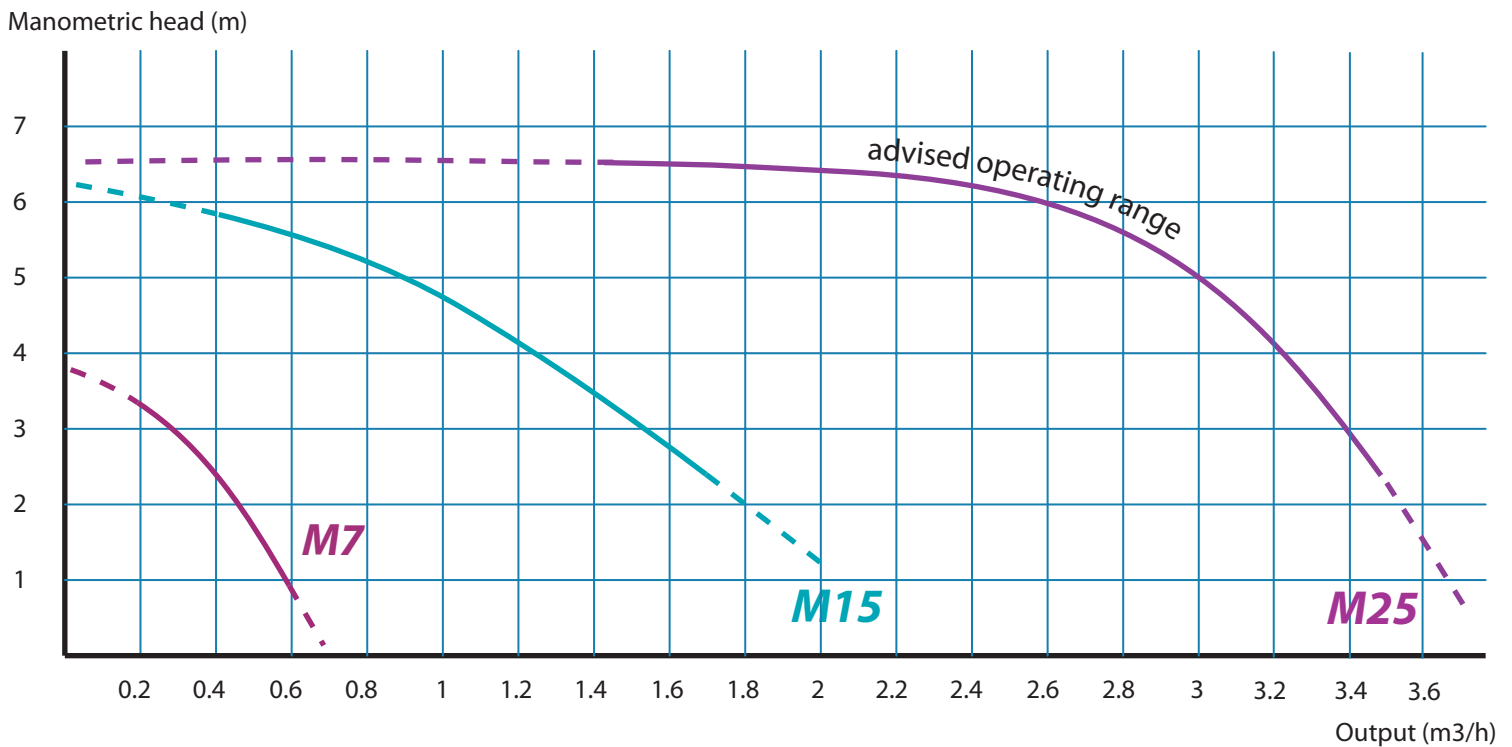
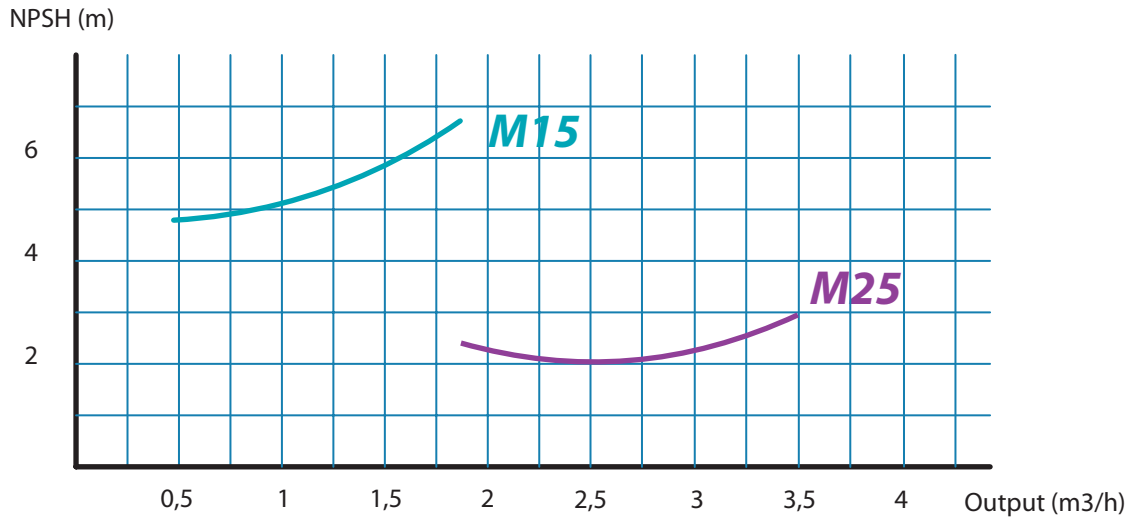



M7 pump

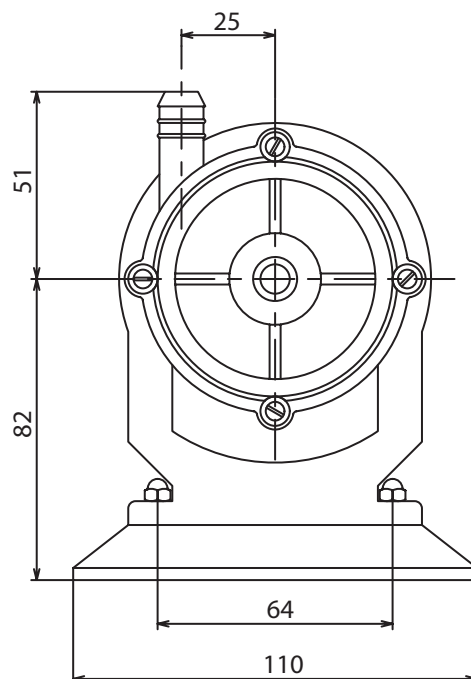
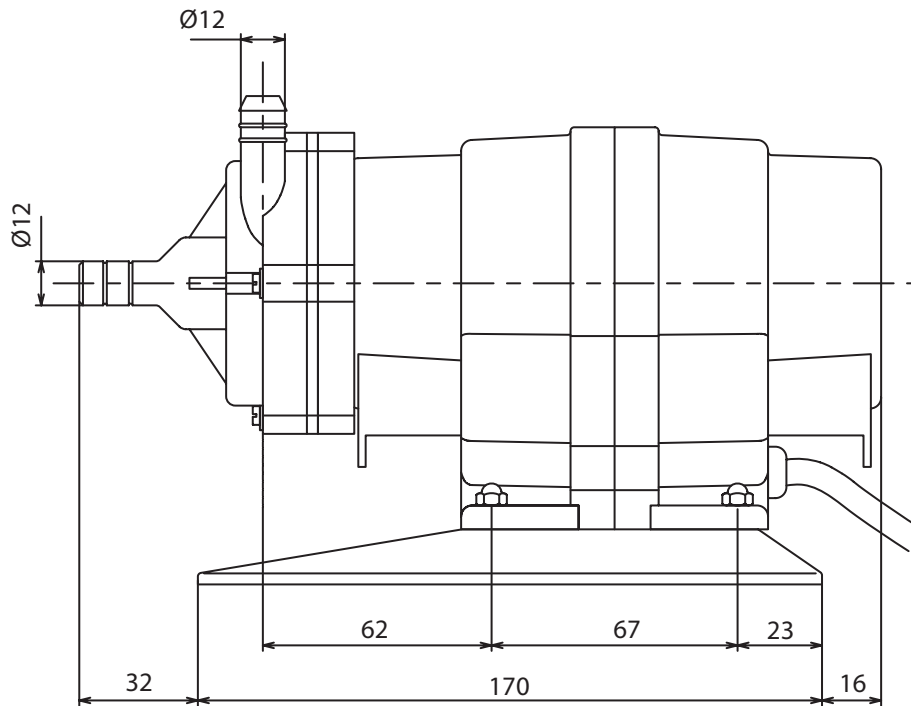

MASS : 1.9 kg



M15 pump

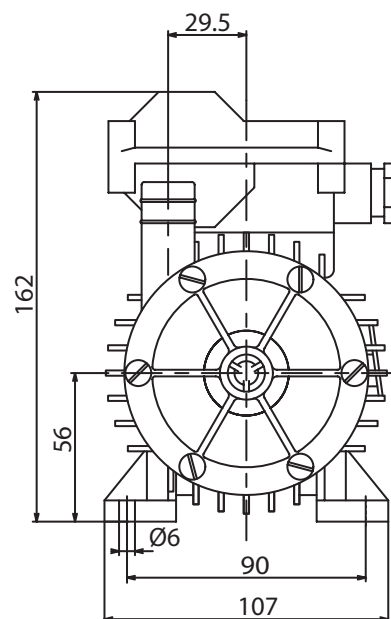
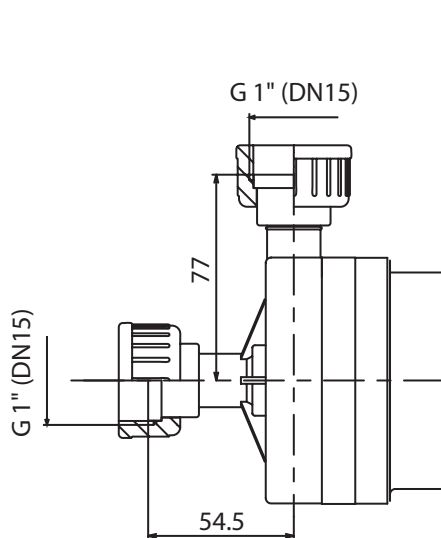
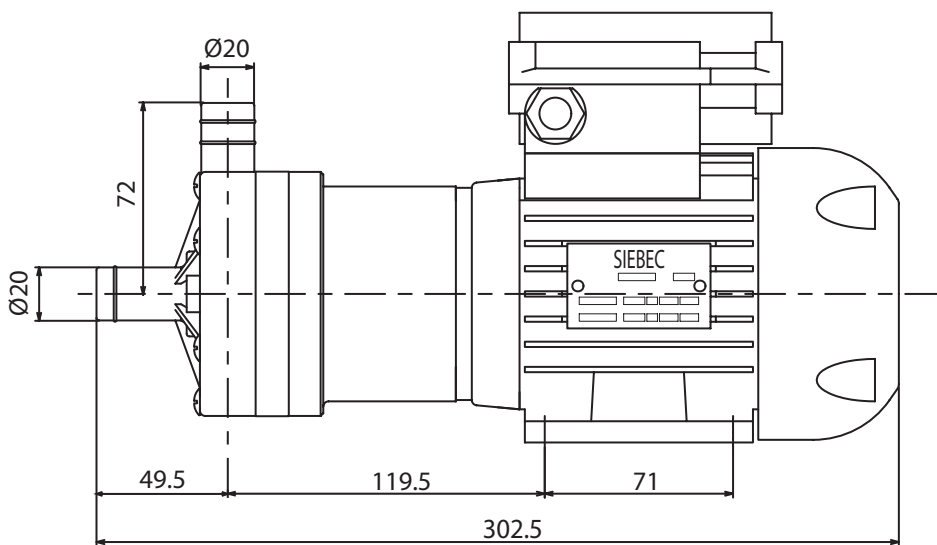

MASS: 3.1 kg



M25 pump

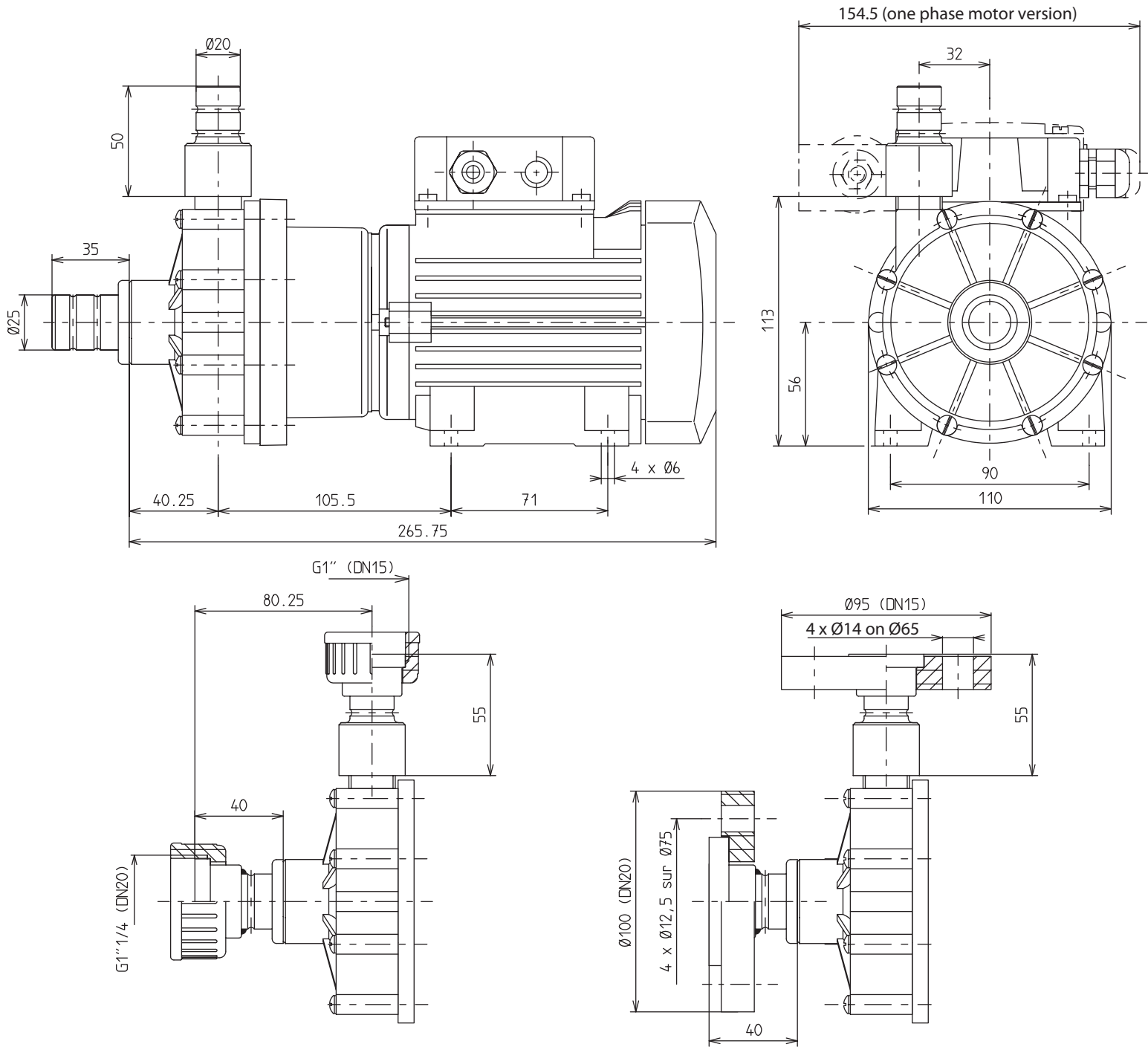

MASS : 3.5 kg