



APPLICATIONS :

**surface treatment,
transfer, pumping of chemicals
water treatment
paper industry
agriculture
agribusiness
cosmetics industry
salt water
metallurgy**

France

SIEBEC SAS
9 rue des platanes
ZAC Vence Ecoparc
38120 SAINT-ÉGRÈVE
Tél. : 33 (0)4 76 26 12 09
Fax : 33 (0)4 76 27 04 82

www.siebec.com

England

SIEBEC UK Ltd
Unit 3 - ST.Alban's BusinessPark
ST. ALBAN'S RD
STAFFORD - ST16 3DR
Ph. : +44 (0)1 785 227 700
Fax : +44 (0)1 785 246 006





M200



M70



M50

Features	Advantages
Pump body made of injected plastic (Polypropylene or PVDF)	Excellent resistance to acids and bases Max. fluid temperature = 80°C (PP), 110°C (PVDF)
Closed centrifugal pump impeller with diffuser part	Very good efficiency Max. flow rate up to 40 m ³ /h Max. manometric head up to 23 m
Impeller driven by high capacity magnetic coupler	No gaskets, no risks of leaks Compatible with fluids of S.G. 1.2 to 1.5 or 2 (spec. mod.)
Ceramic / ceramic impeller bearing oversized with ceramic / PTFE stop	Very long lifetime (running dry prohibited)
Integrated electric motor	Reduced dimensions
Automatic repriming	Suction head up to 2 m



M35 - M50 - M70

magnetic coupled motor-pumps

Self repriming

230 V single-phase motor or 230/400 V three-phase motor - 50 Hz or 60 Hz upon request - 3,000 rpm

Standard inlet/outlet with grooved nozzles. Optional union nuts or flange fittings

For PVDF versions possibility of EPDM gaskets upon request

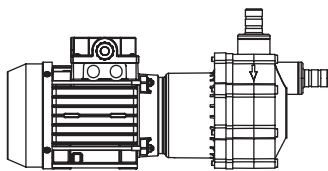

M35 Pump

Technical features

- Motor power	0.18 kW 1 phase or 3 phase motor	
- Max. output	3 m ³ /h	
- Max. head	10 m	
- Max. fluid temperature	PP body 80°C	PVDF body 110°C
- Gaskets	EPDM - FPM	FPM
- S.G.	< 1.4	

DIMENSIONS



CURVES

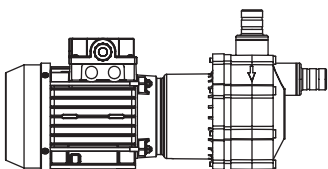

M50 Pump

Technical features

- Motor power	0.18 kW 1 phase or 3 phase motor	
- Max. output	5 m ³ /h	
- Max. head	10 m	
- Max. fluid temperature	PP body 80°C	PVDF body 110°C
- Gaskets	EPDM - FPM	FPM
- S.G.	< 1.2	

DIMENSIONS



CURVES

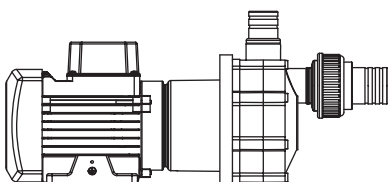

M70 Pump

Technical features

- Motor power	0.25 kW 3 phase motor	
- Max. output	7 m ³ /h	
- Max. head	9,5 m	
- Max. fluid temperature	PP body 80°C	PVDF body 110°C
- Gaskets	EPDM - FPM	FPM
- S.G.	< 1.2	

DIMENSIONS



CURVES



M100 - M140 - M200 magnetic coupled motor-pumps

Self-priming

230/400 V three-phase motor - 50 Hz or 60 Hz upon request - 3,000 rpm

Serial-mounted strainer built into the volute case

Standard inlet/outlet with grooved nozzles. Optional union nuts or flange fittings

For PVDF versions possibility of EPDM gaskets upon request

Special models M100 and M140 PVDF for liquids to 2.0 S.G.

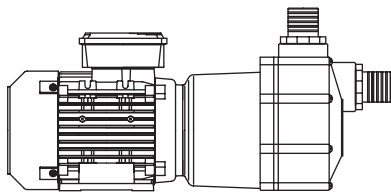

M100 Pump

Technical features

- Motor power	0.75 kW	
- Max. output	10 m ³ /h	
- Max. head	18 m	
- Max. fluid temperature	PP body 80 °C	PVDF body 110 °C
- Gaskets	EPDM - FPM	FPM
- S.G.	< 1.5	< 1.5 (=2 spec. mod.)

DIMENSIONS



CURVES

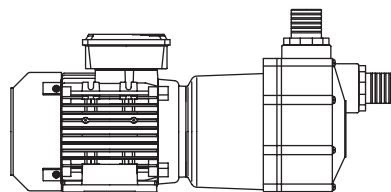

M140 Pump

Technical features

- Motor power	1.1 kW	
- Max. output	14 m ³ /h	
- Max. head	19 m	
- Max. fluid temperature	PP body 80 °C	PVDF body 110 °C
- Gaskets	EPDM - FPM	FPM
- S.G.	< 1.5	< 1.5 (=2 spec. mod.)

DIMENSIONS



CURVES

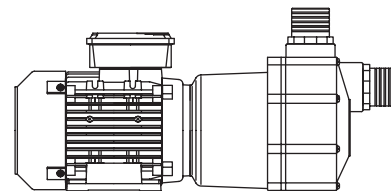

M200 Pump

Technical features

- Motor power	1.1 kW	
- Max. output	20 m ³ /h	
- Max. head	19 m	
- Max. fluid temperature	PP body 80 °C	PVDF body 110 °C
- Gaskets	EPDM - FPM	FPM
- S.G.	< 1.3	

DIMENSIONS



CURVES



M35 - M50 - M70 Pumps

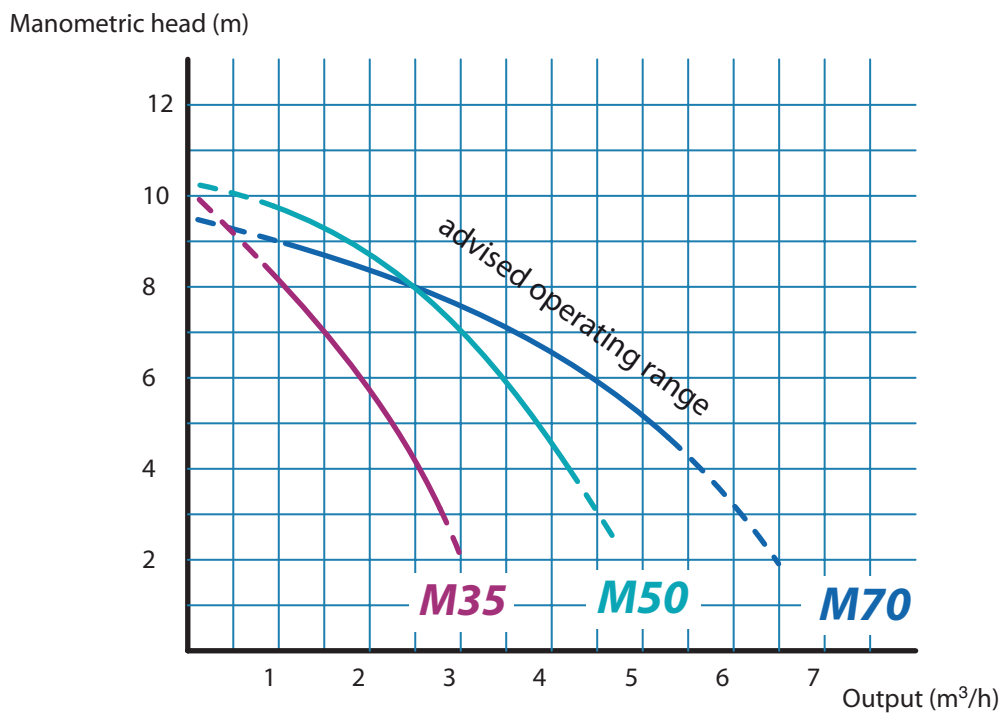
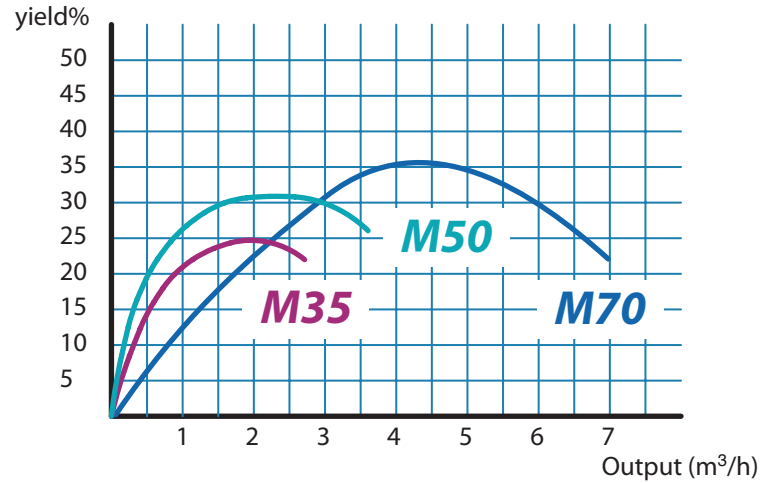
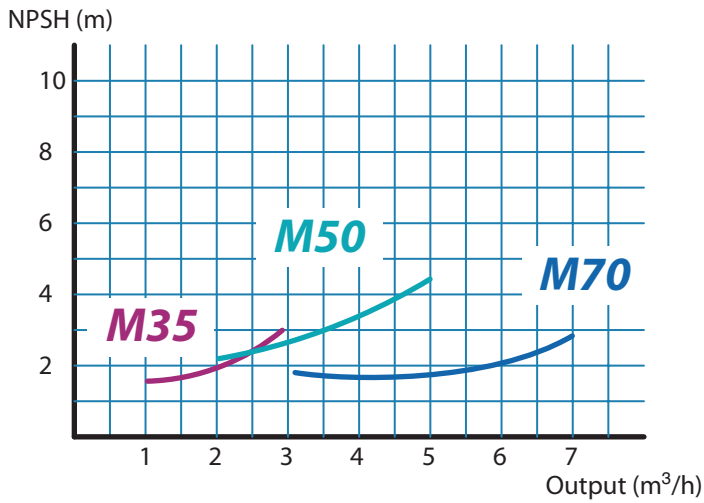



M100 - M140 - M200 Pumps

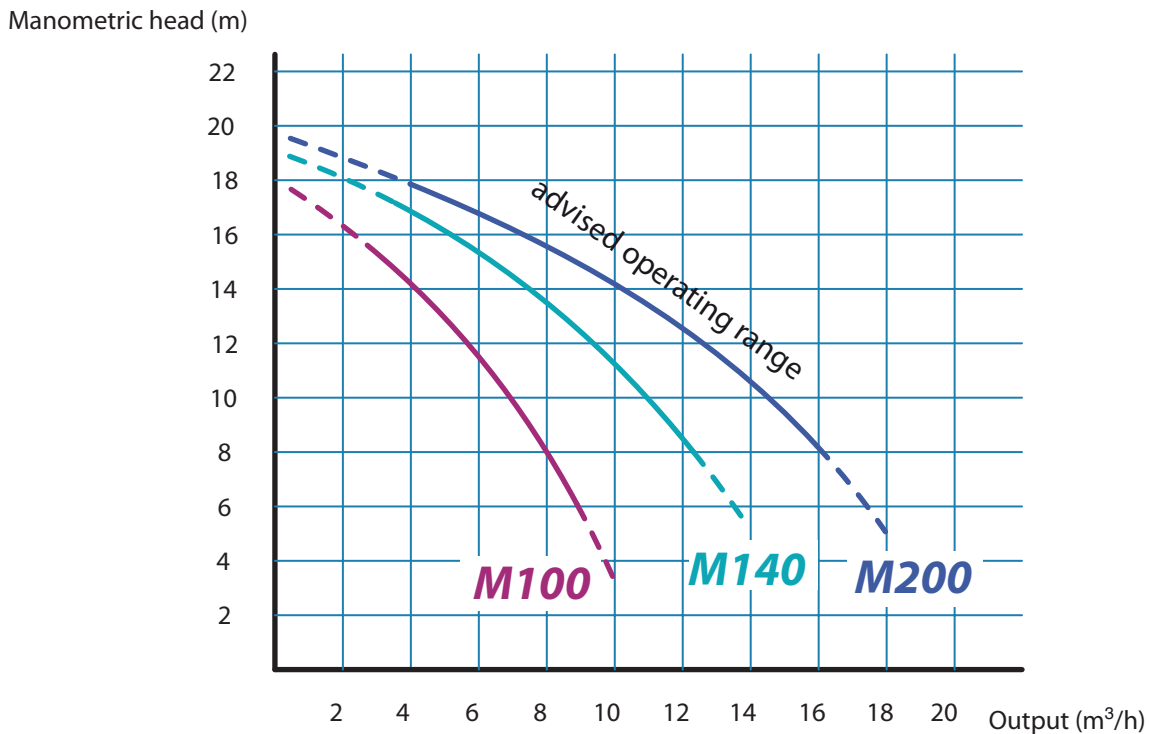
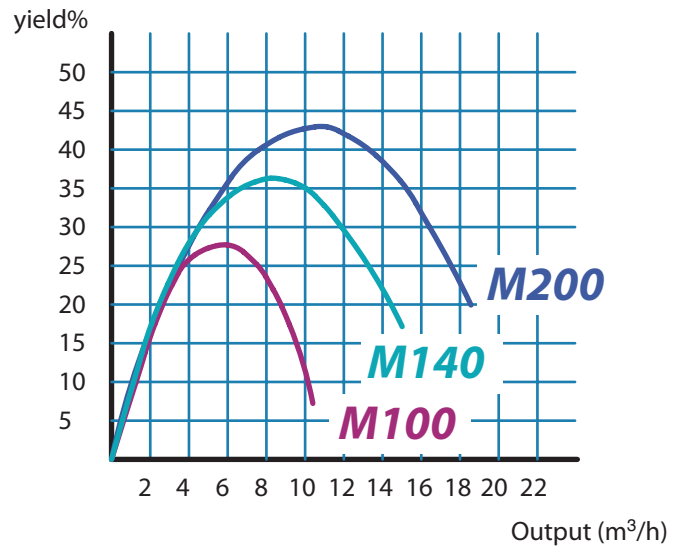
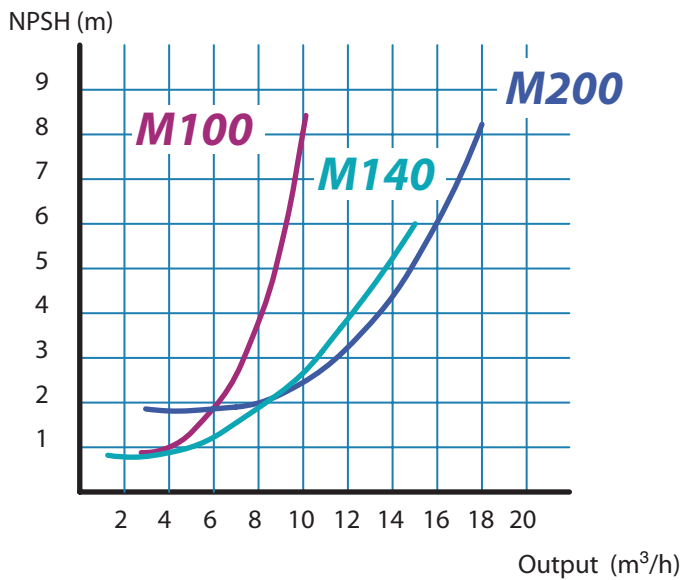



M35 - M50 Pumps

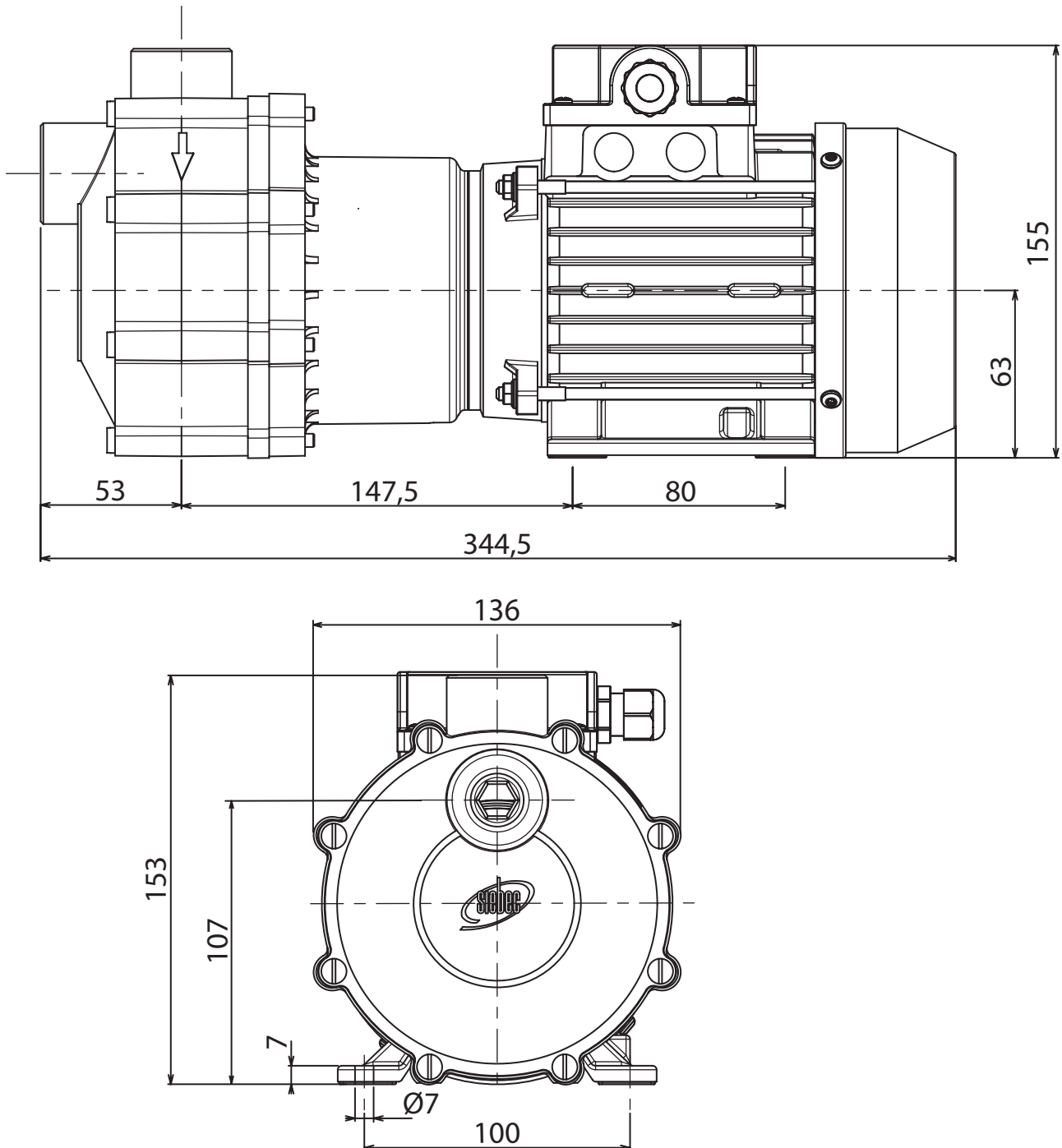



M35 - M50 Pumps connections

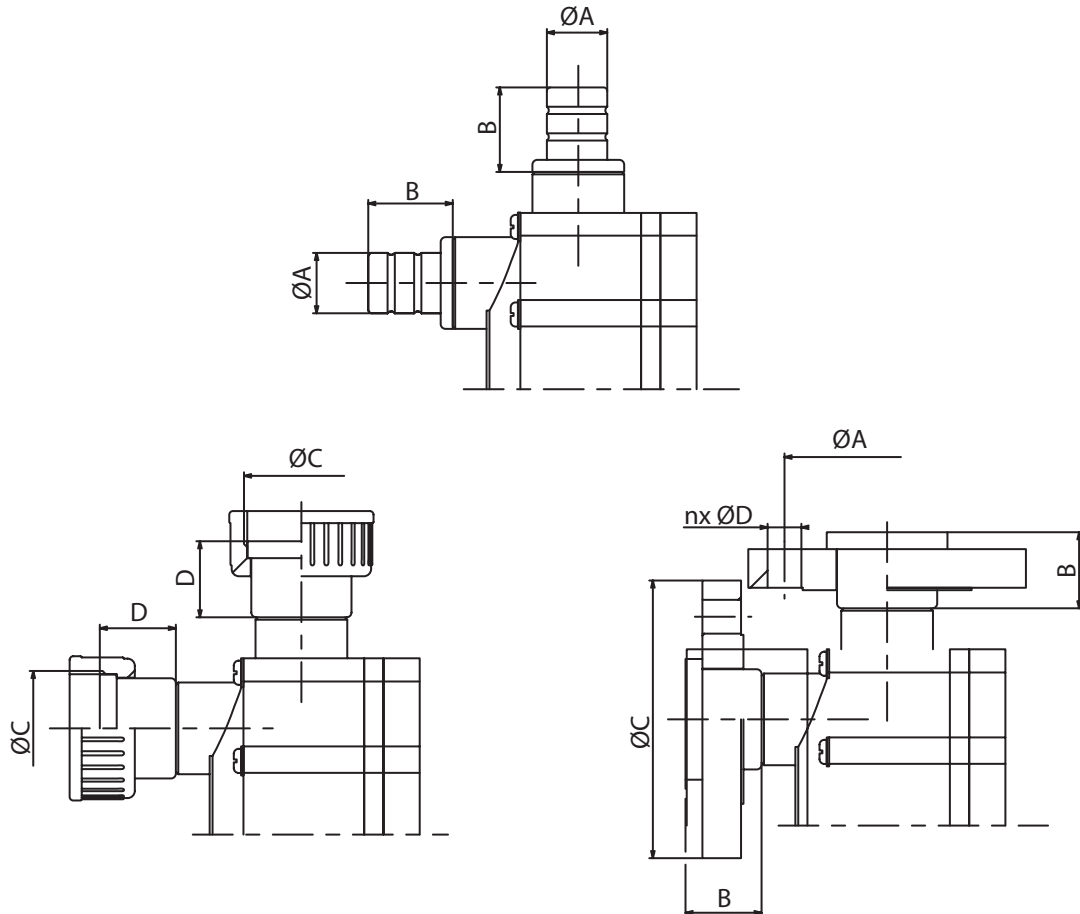

Model		Grooved nozzle ØA - B	Union nut ØC (DN) - D	Flange ØC - ØA - nxØD - B
M35	Inlet	Ø20 - 35	G1"1/4 - DN20 - 31,5	Ø100 - Ø75 - 4xØ14 - 31,5
	Outlet			
M50	Inlet	Ø25 - 35	G1"1/2 - DN25 - 31,5	Ø115 - Ø85 - 4xØ14 - 31,5
	Outlet			



M70 Pump

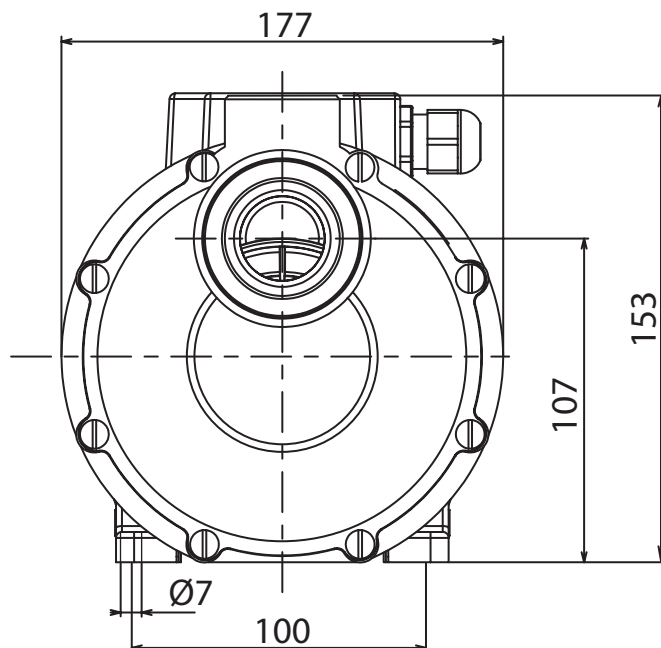
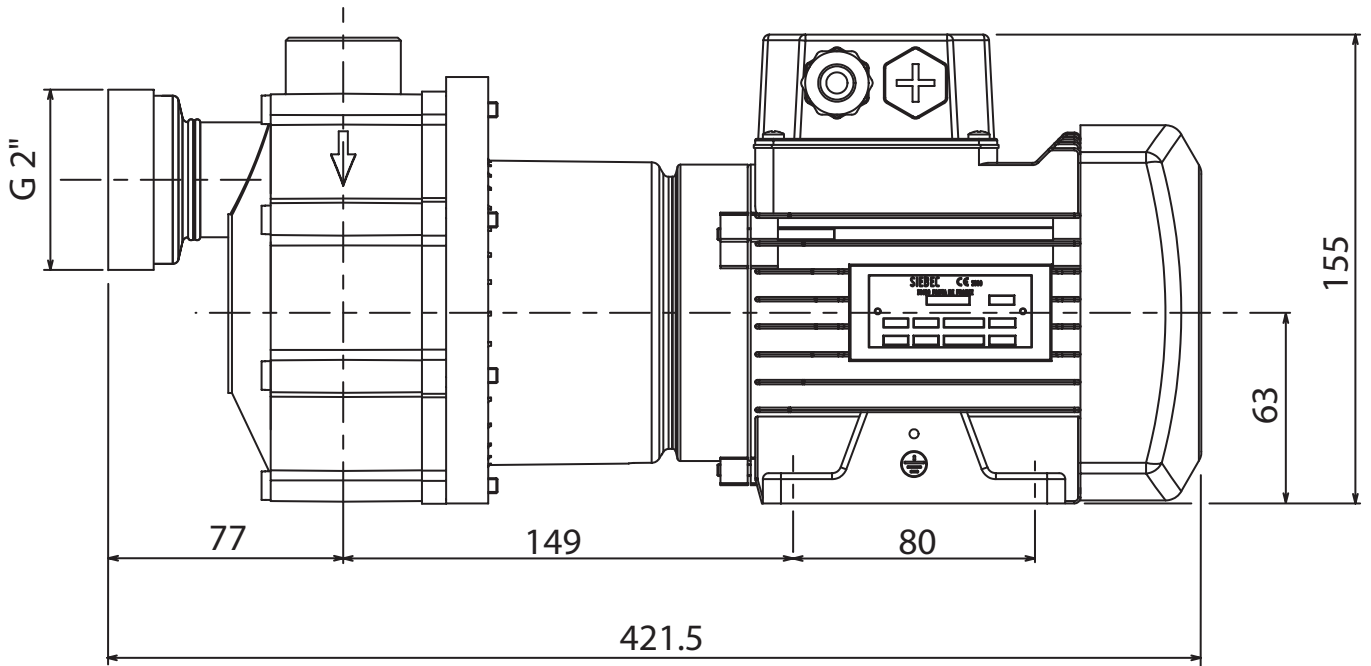



M70 Pump connections

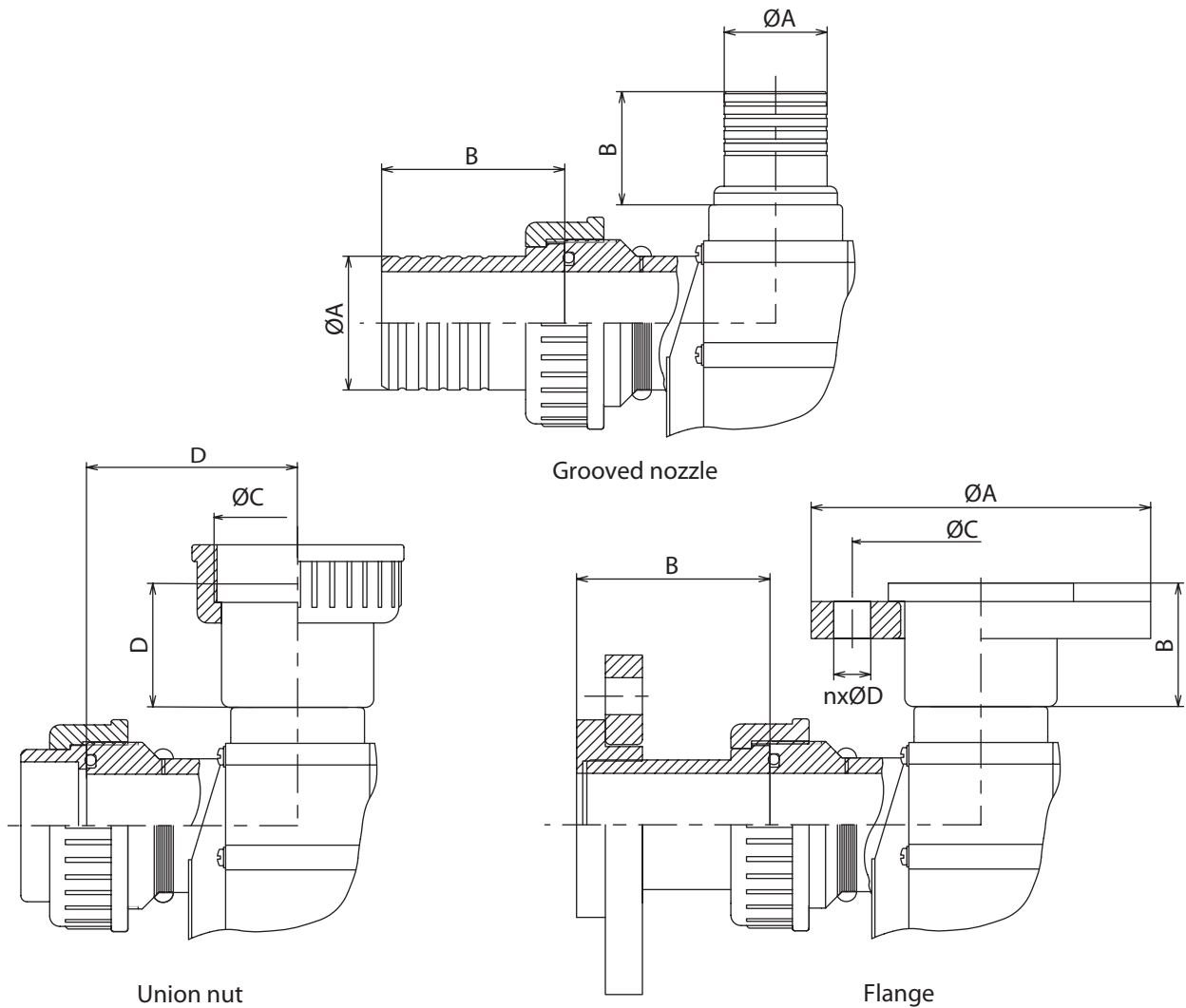

Model		Grooved nozzle	Union nut	Flange
		$\text{ØA} - B$	$\text{ØC (DN)} - D$	$\text{ØA} - \text{ØC} - n \times \text{ØD} - B$
M70	Inlet	$\text{Ø}40 - 60$	G 2" - DN32 - 54	$\text{Ø}140 - \text{Ø}100 - 4 \times 18 - 55$
	Outlet	$\text{Ø}32 - 35$	G 1 1/2 - DN25 - 30	$\text{Ø}115 - \text{Ø}85 - 4 \times 14 - 30$



M100 - M140 - M200 Pumps

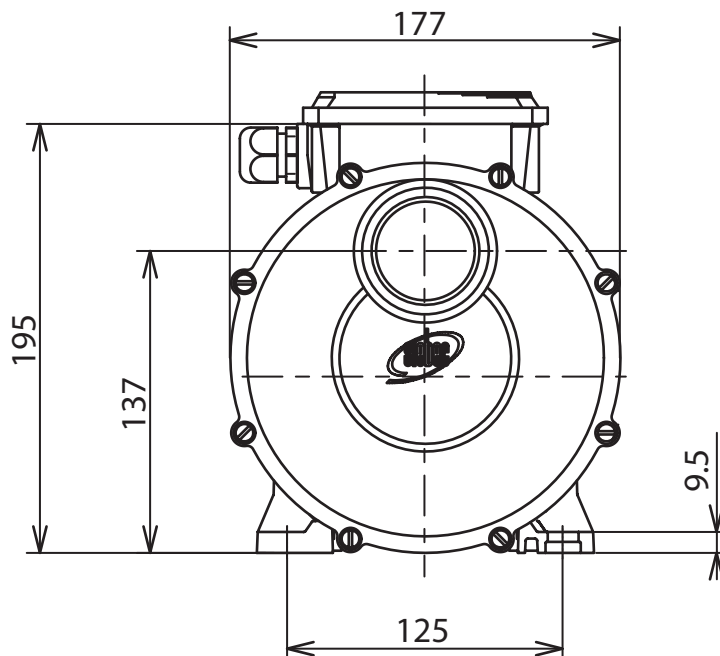
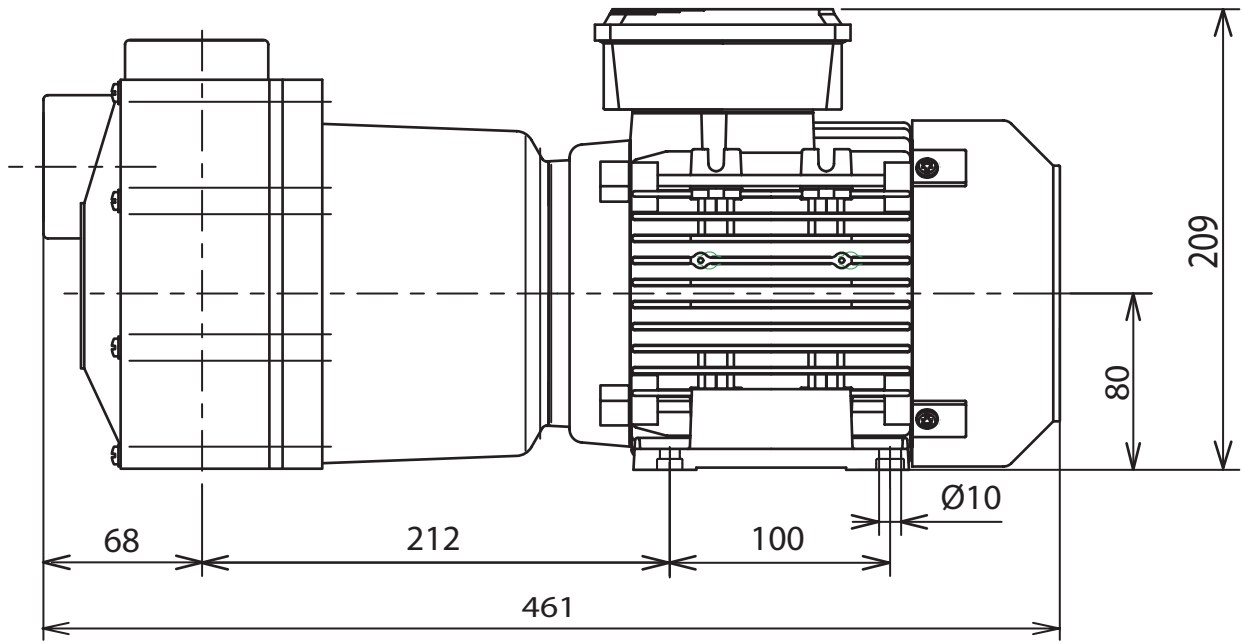



M100 to M200 Pumps connections

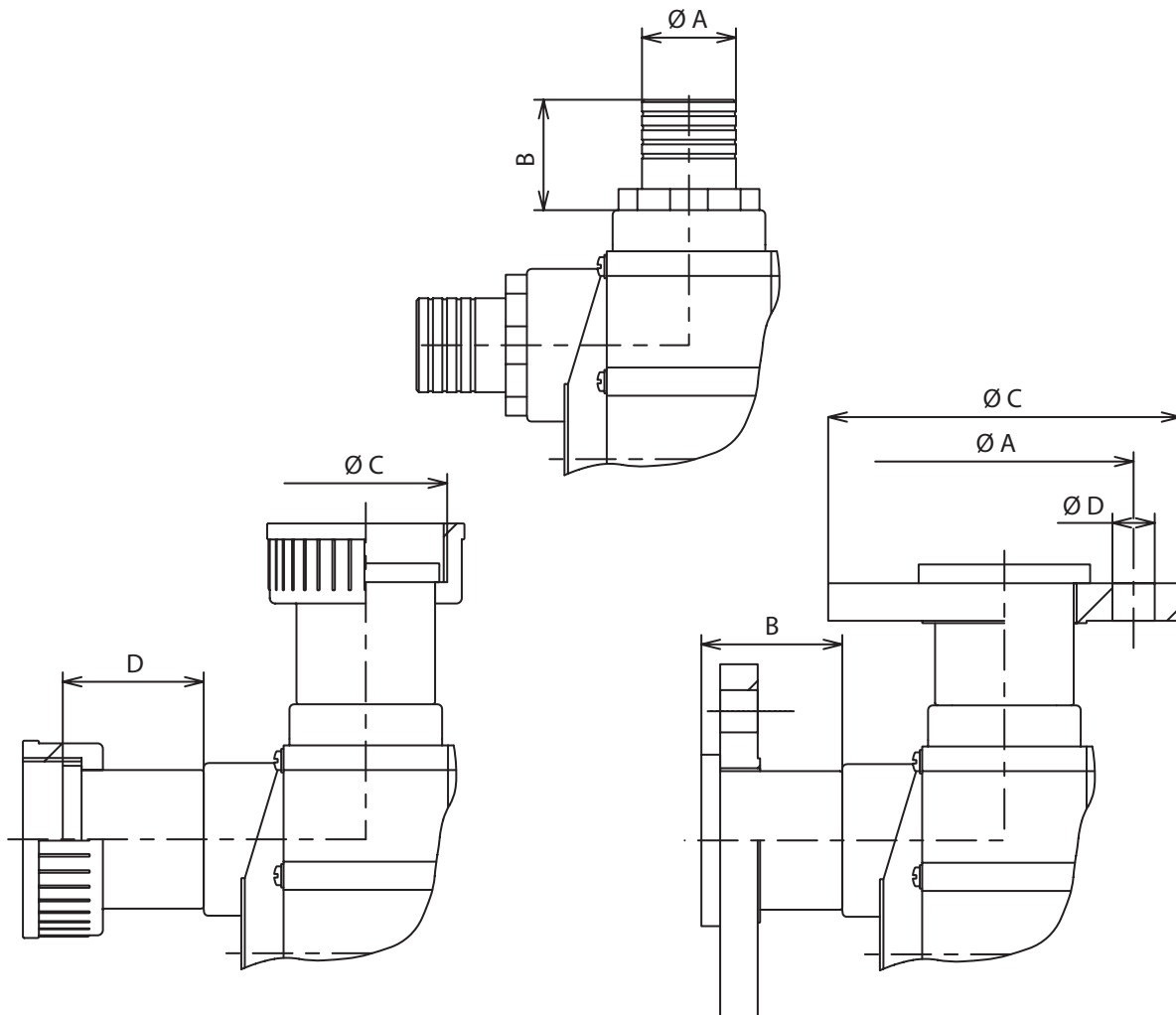

Models		Grooved nozzle ØA - B	Union nut ØC (DN) - D	Flange ØC - ØA - nxØD - B
M100 - M140	Inlet	40 - 47	G2"1/4 - DN40 - 60	150 - 110 - 4x18 - 60
	Outlet			
M200	Inlet	50 - 55	G2"3/4 - DN50 - 60	165 - 125 - 4x18 - 60
	Outlet			